

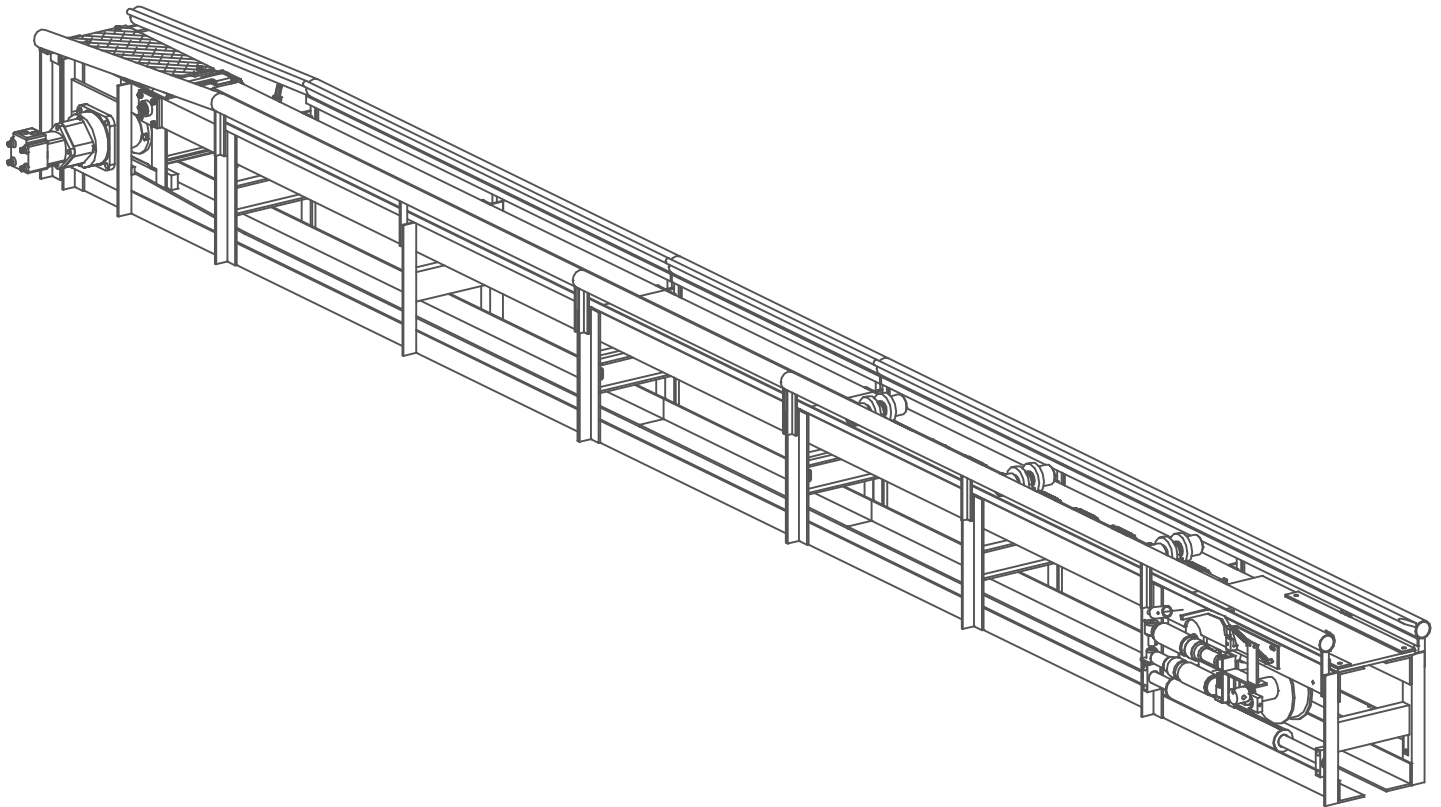

RG-440 CONVEYOR PARTS LIST

JANUARY 2015

America's Best Conveyor



MACNEIL WASH SYSTEMS
90 WELHAM RD
BARRIE, ON, L4N 8Y4, CANADA
PHONE: 705-722-7649
800-361-7797
FAX: 705-722-0582
www.macneilwash.com

RG-440 CONVEYOR

ENTRANCE D/S

PAGE #2

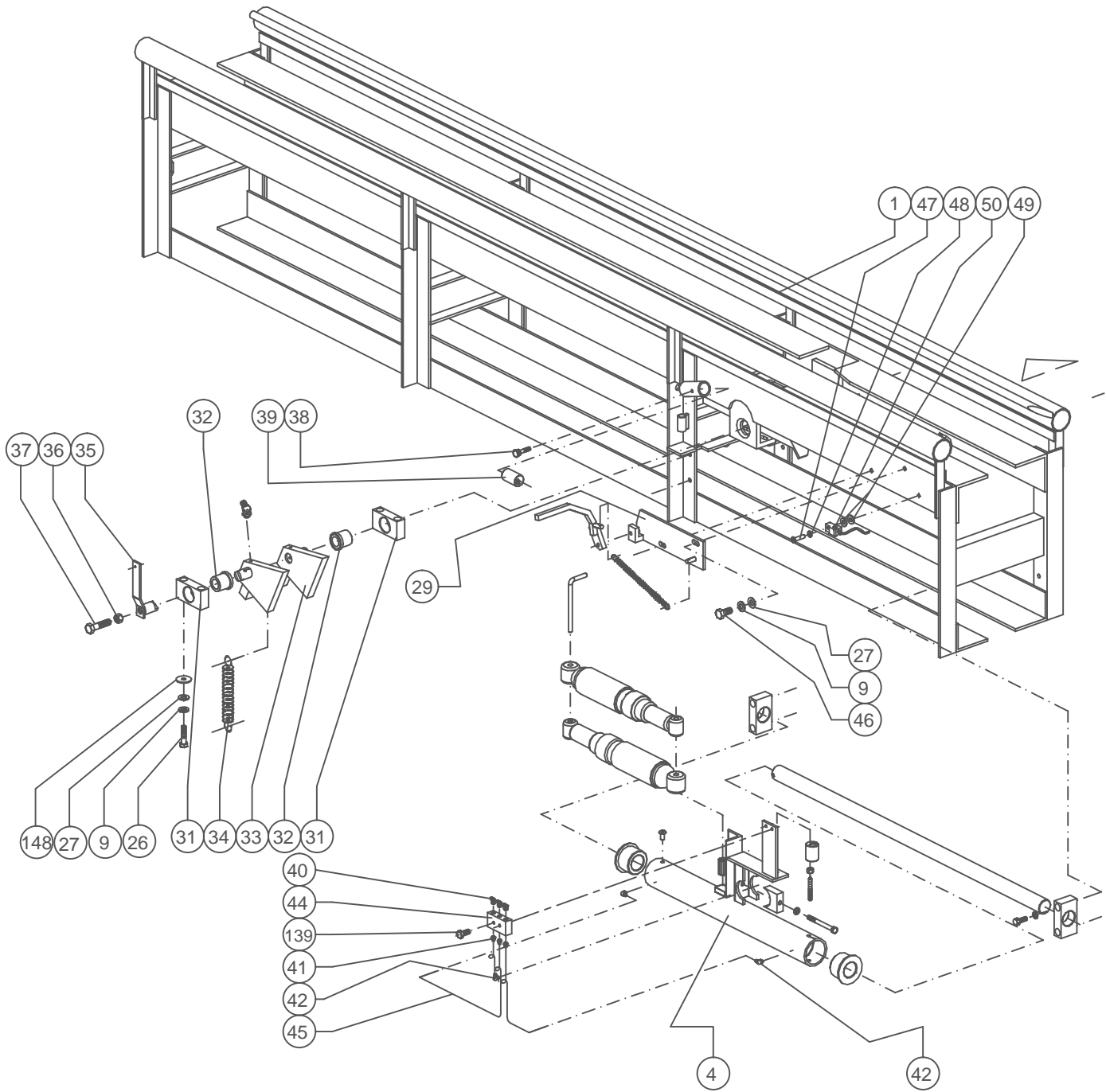

MACNEIL WASH SYSTEMS

RG-440 CONVEYOR

PAGE #3

ENTRANCE P/S

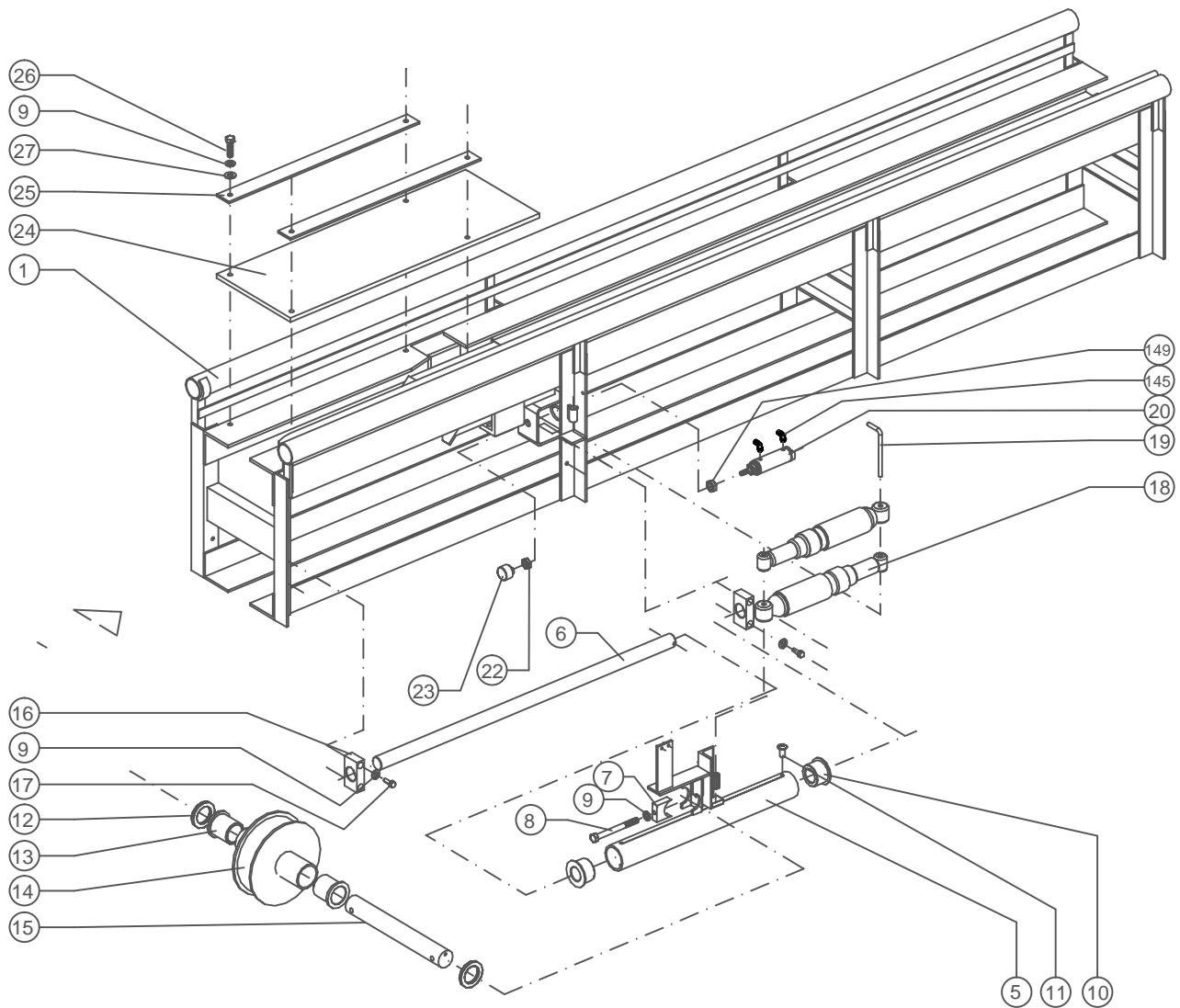

MACNEIL WASH SYSTEMS

RG-440
CONVEYOR
INTERMEDIATE

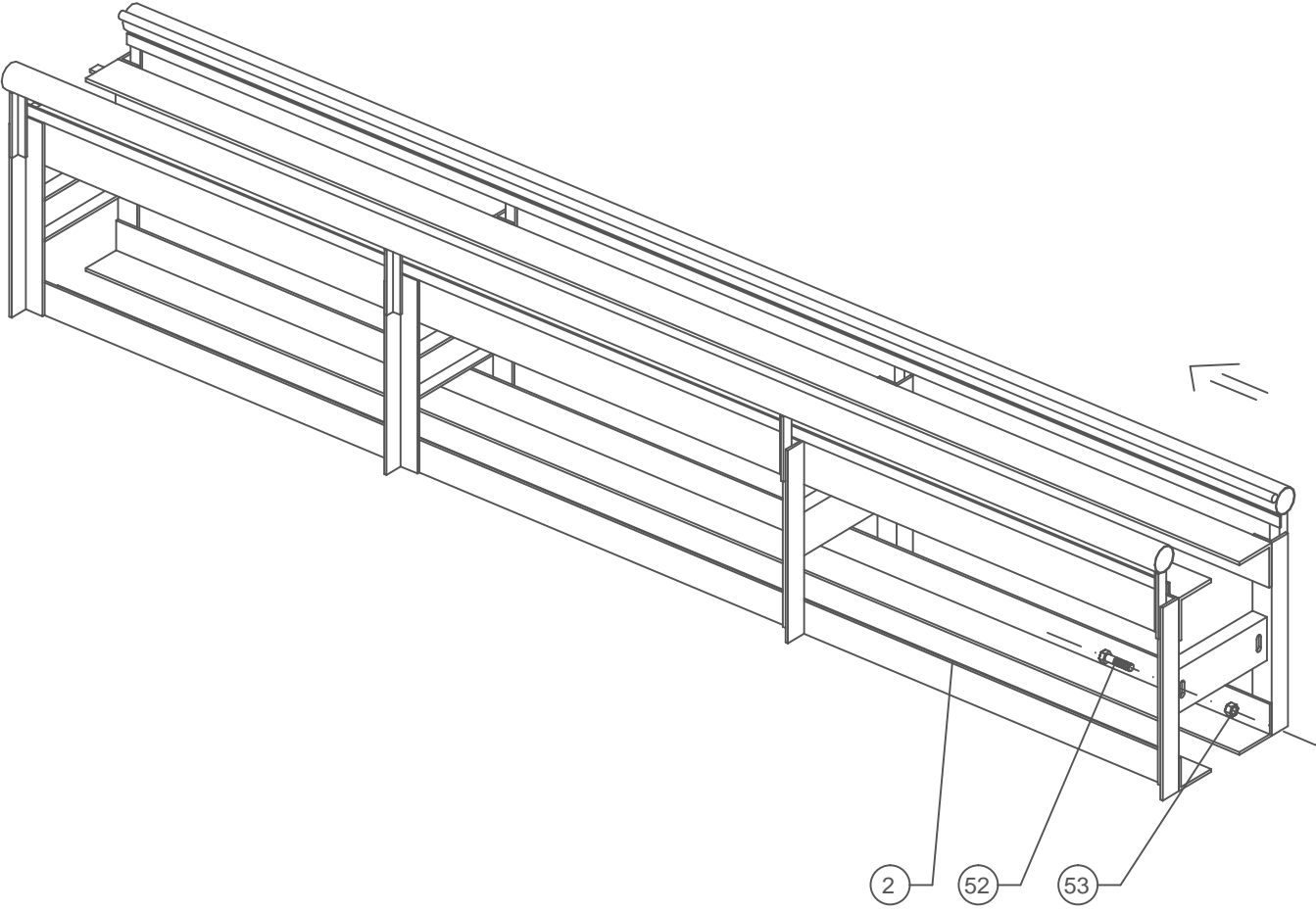

RG-440
CONVEYOR
EXIT FRAME

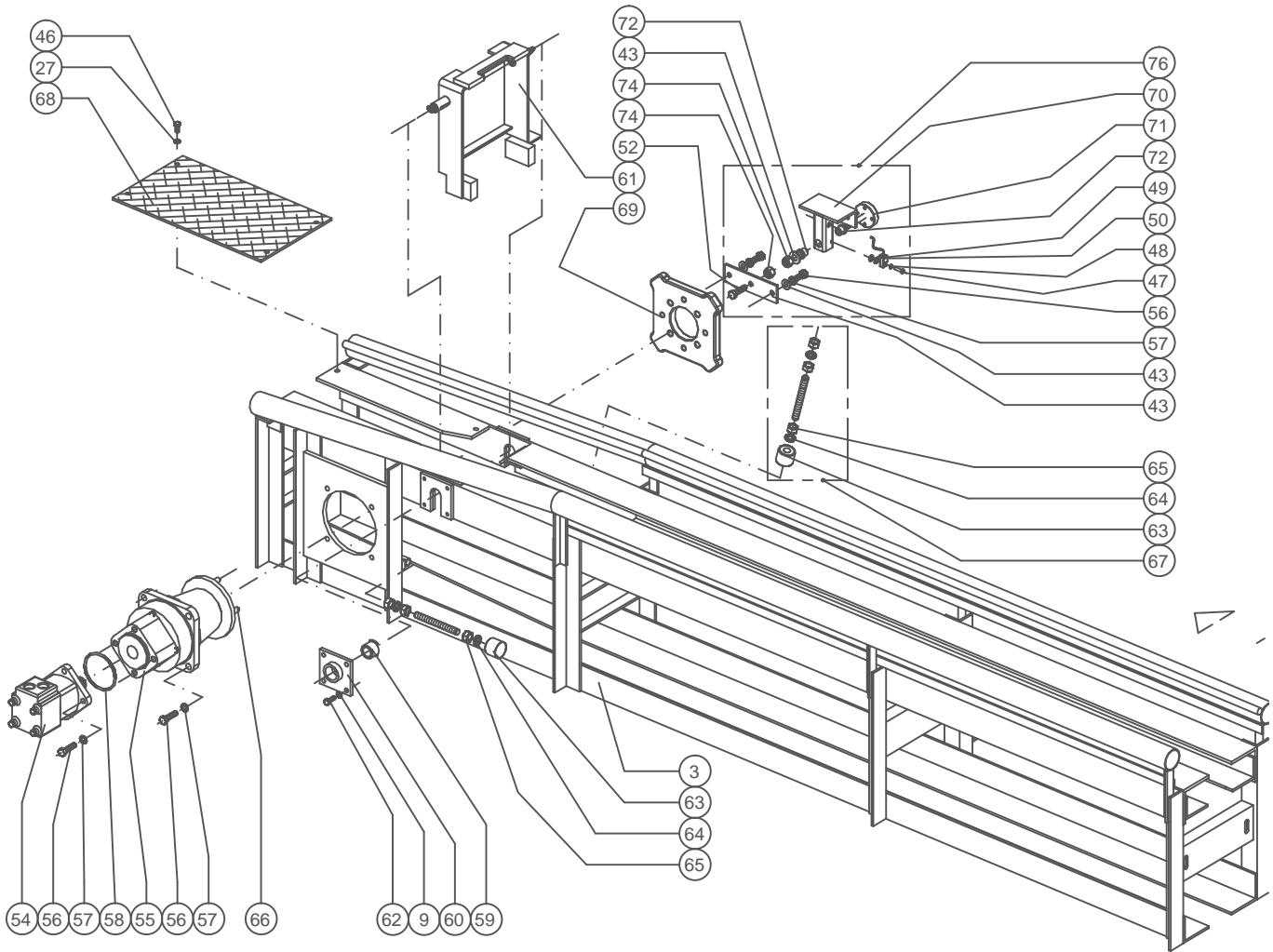

RG-440 CONVEYOR

PAGE #6

ROTARY ENCODER KIT

PART NO. :44-584-00-MP(53L) DC

PART NO. :44-588-00-MP(64L) AC

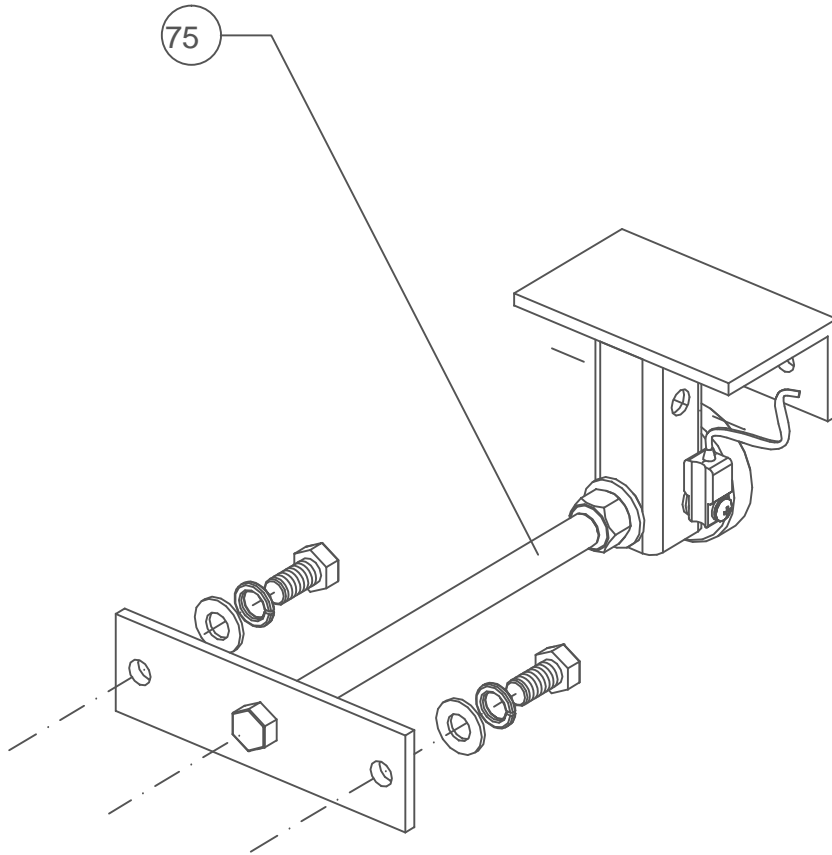

MACNEIL WASH SYSTEMS

**RG-440
CONVEYOR**

PAGE #7

MANUAL CALL-UP KIT

PART NO. : 44-953-00-MP(STANDARD)

44-954-00-MP(MIRROR IMAGE)

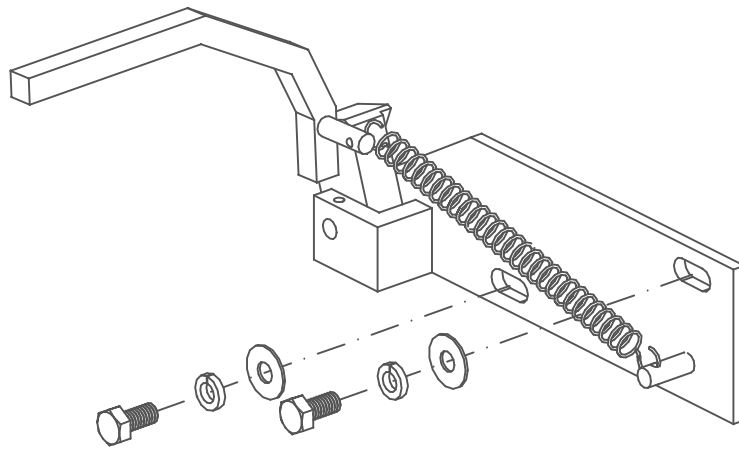

MACNEIL WASH SYSTEMS

RG-440
CONVEYOR
GREASE MANIFOLD ASS'Y

PAGE #8

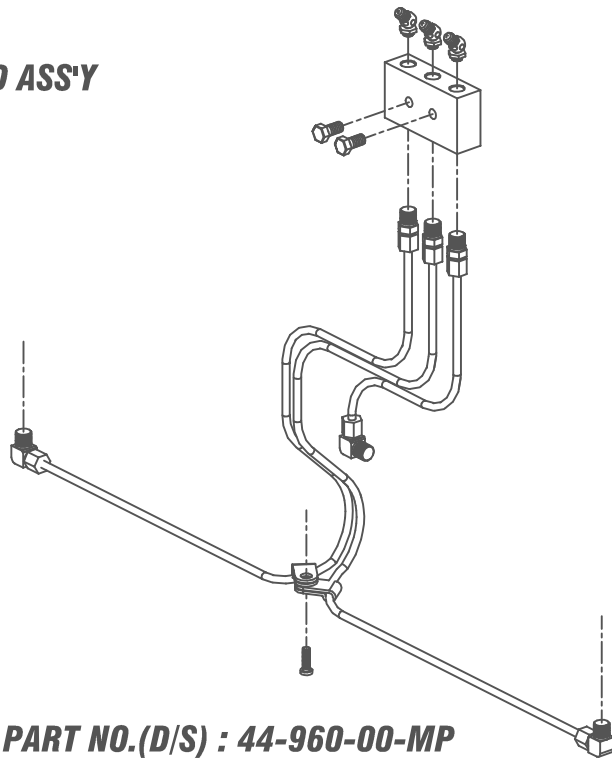

PART NO.(D/S) : 44-960-00-MP

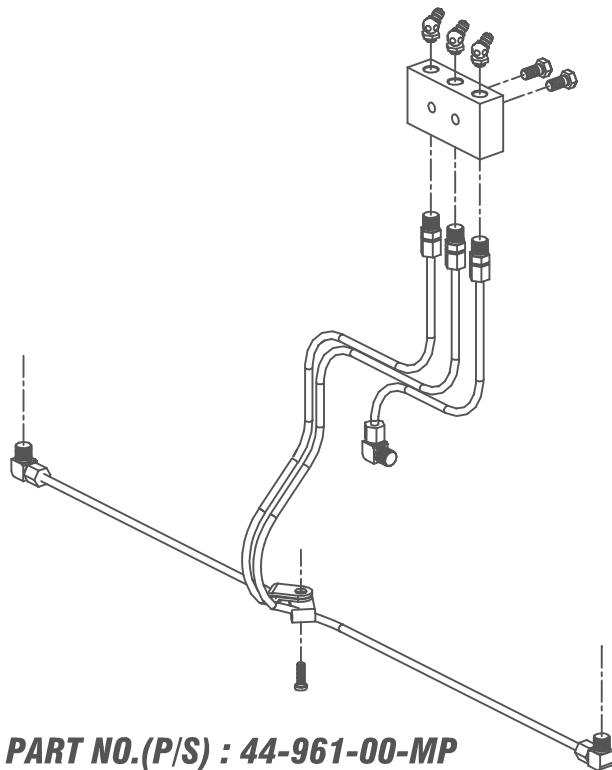

PART NO.(P/S) : 44-961-00-MP

MACNEIL WASH SYSTEMS

RG-440 CONVEYOR

ROLLER CHAIN ASS'Y

PART NO. : 44-060-00-MPRED

PAGE #9

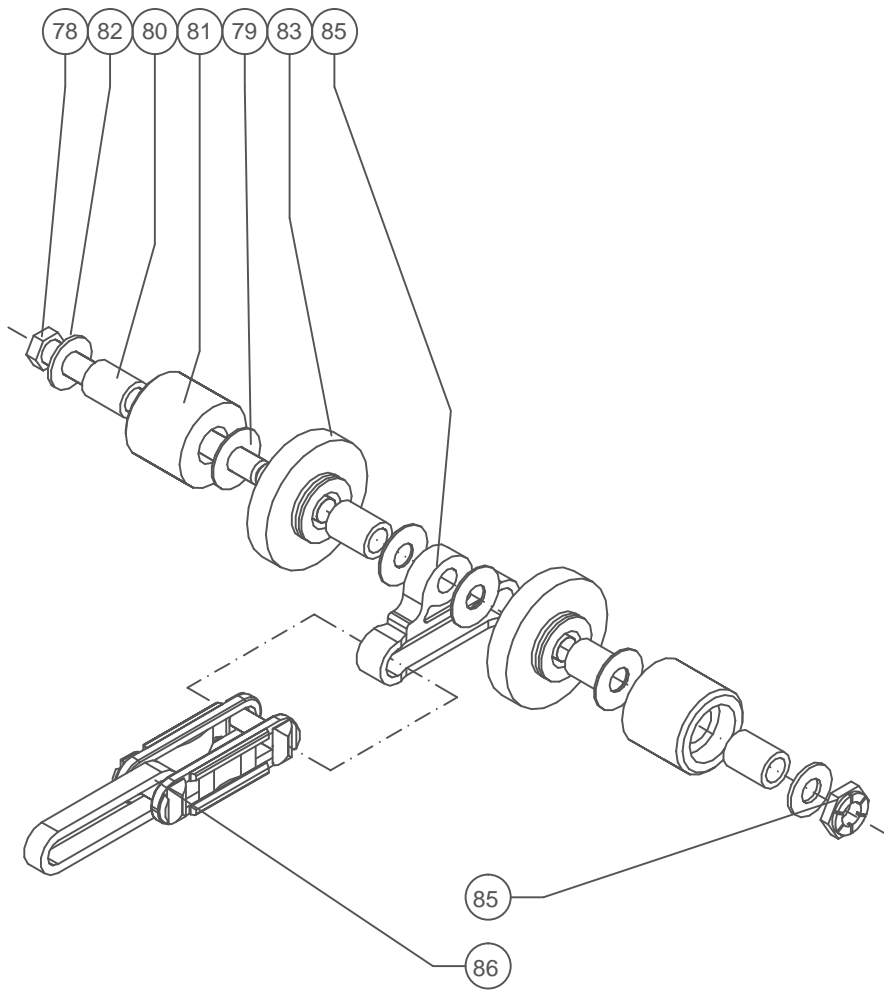

MAGNEIL WASH SYSTEMS

RG-440
CONVEYOR

TREADLE ASS'Y KIT
PART NO. : 44-921-00-MP

PAGE #10

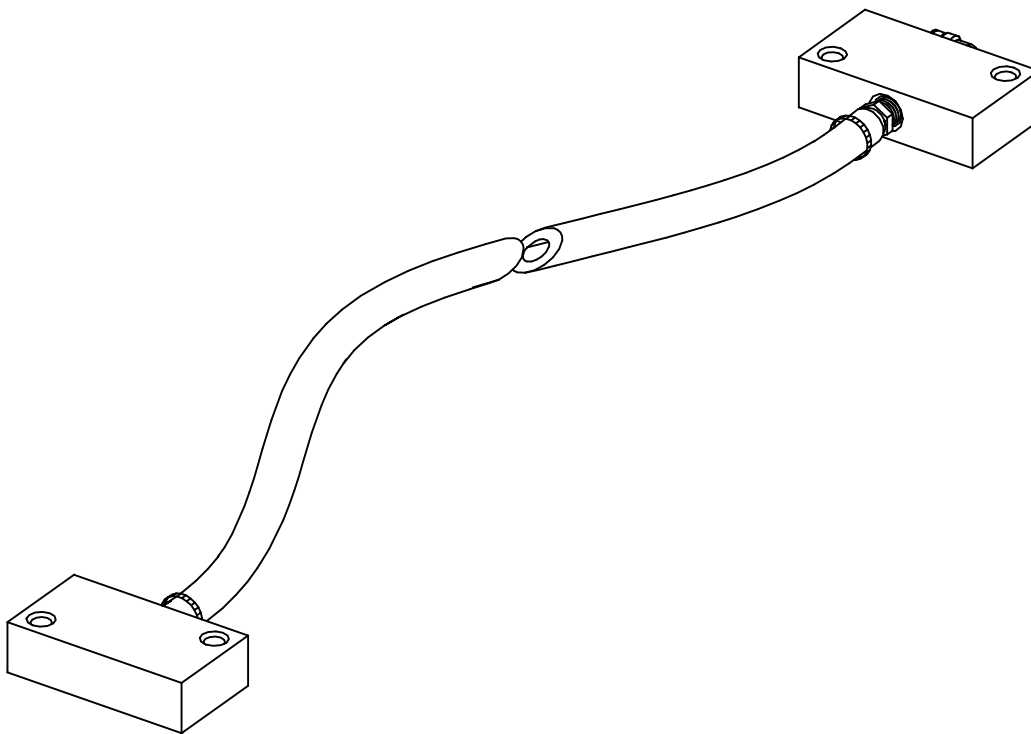

MACNEIL WASH SYSTEMS

RG-440 CONVEYOR

CONTROL STATION

PART NO. :44-571-00-MP(FWP)
PART NO. :44-572-00-MP(RWP)

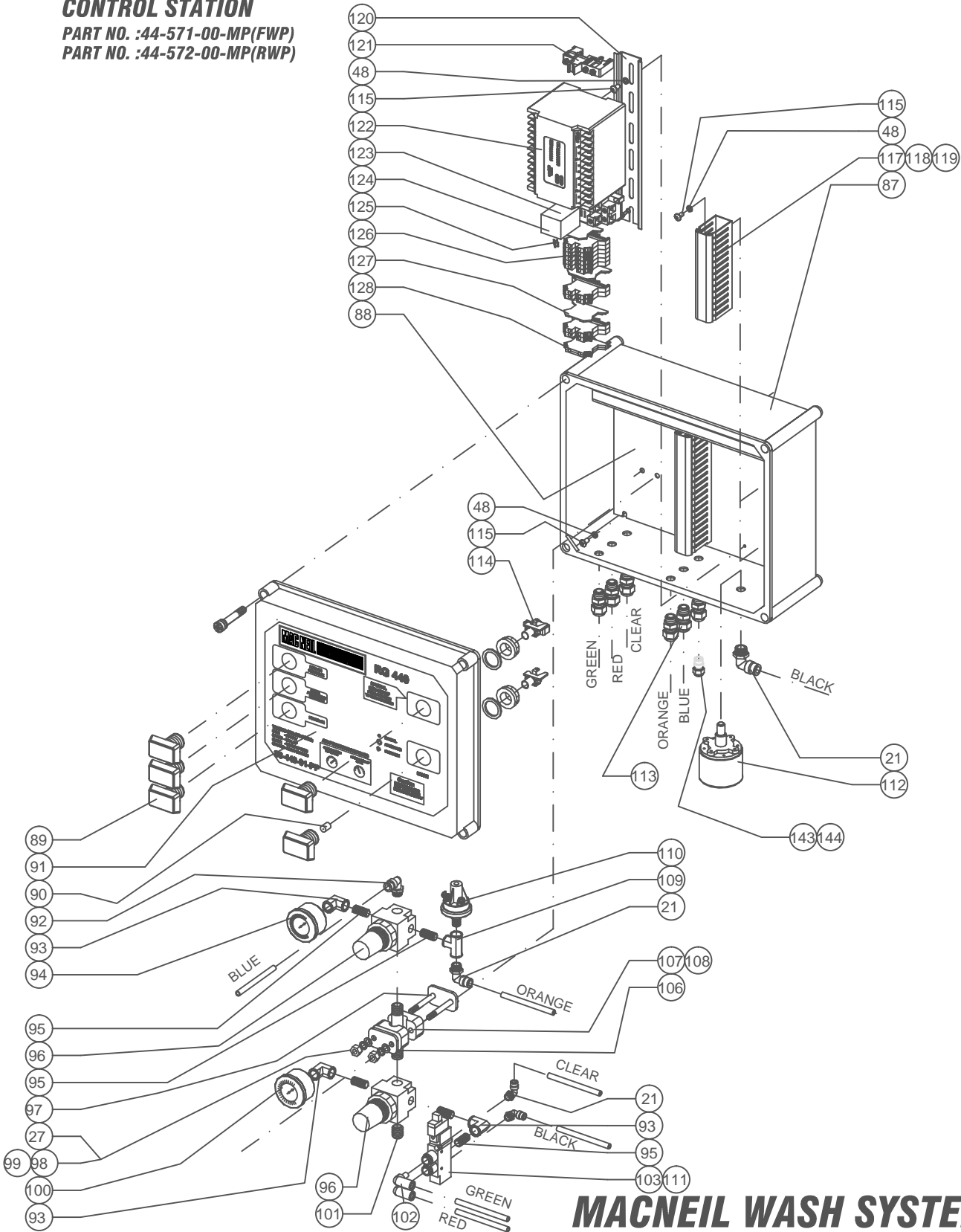

RG-440 CONVEYOR

CONTROL STATION(INPUT-OUTPUT)

PAGE #12

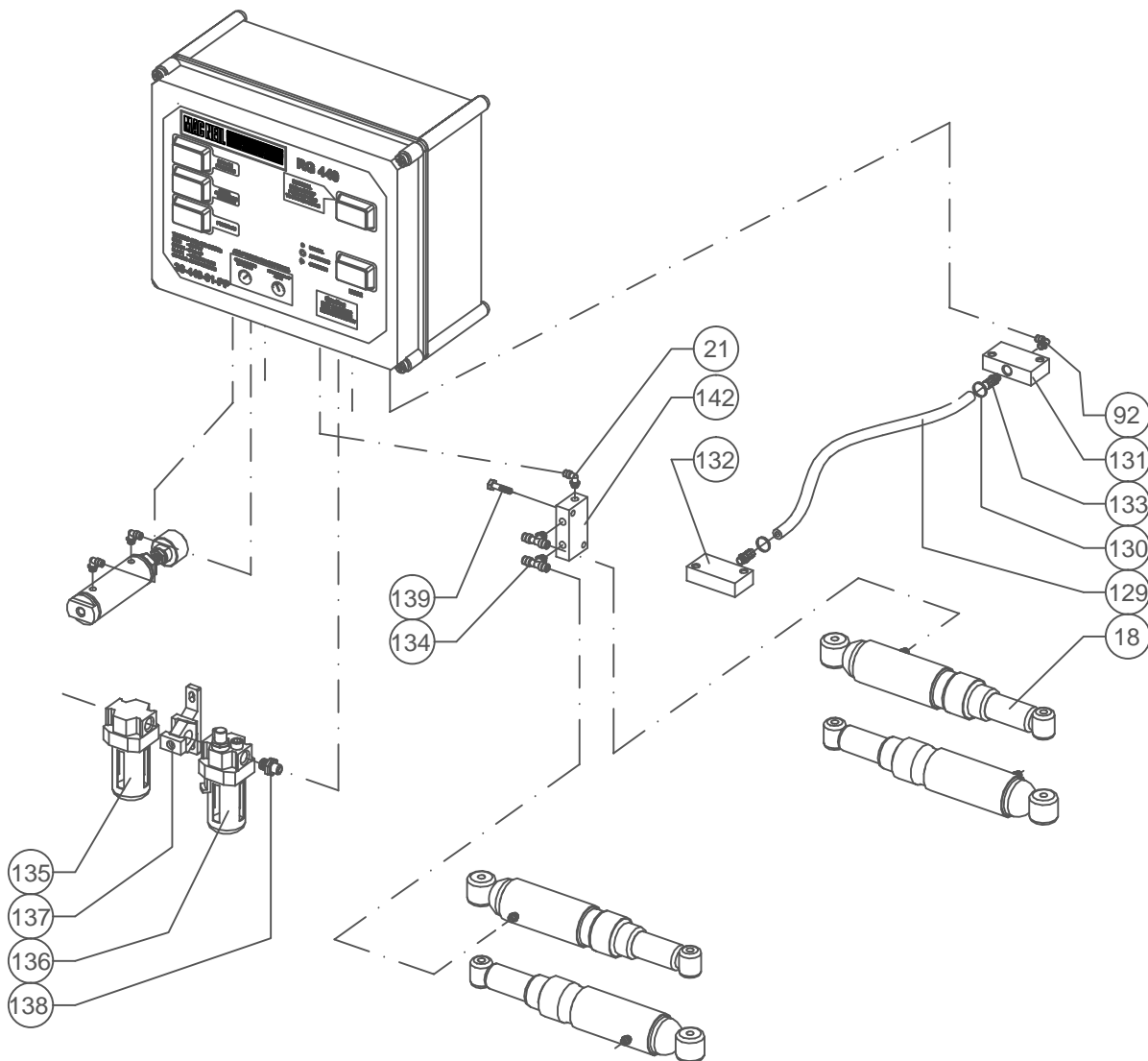

MACNEIL WASH SYSTEMS

RG-440 CONVEYOR

PAGE #13

SLIDER KIT D/S (PART NO. 44-938-00-MP)

SLIDER KIT P/S (PART NO. 44-939-00-MP)

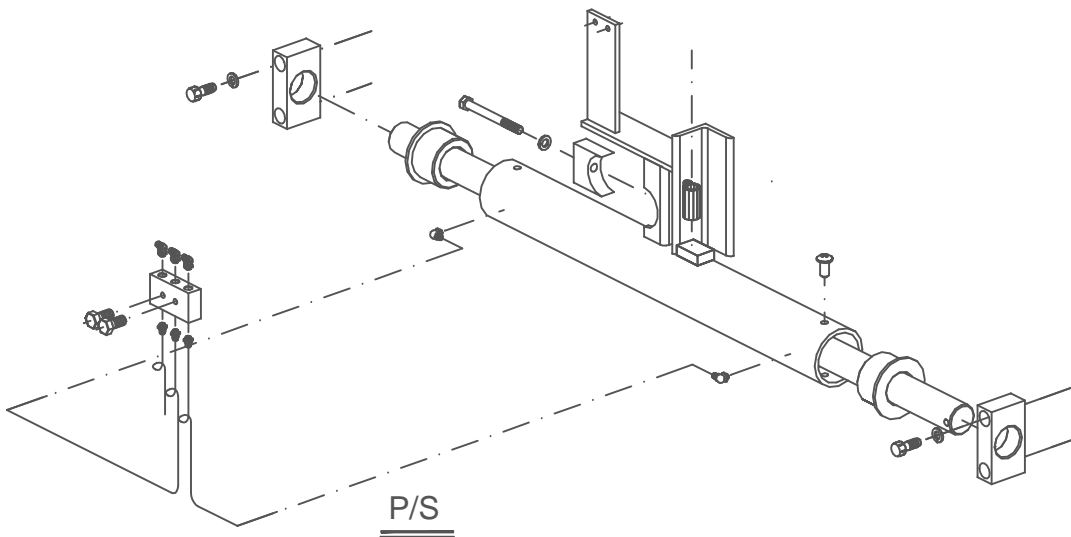
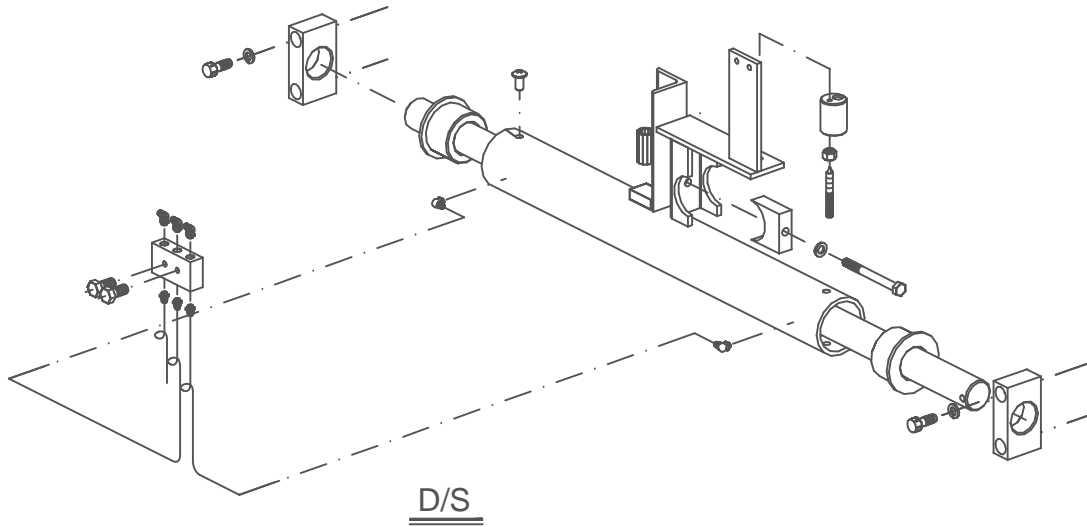

MACNEIL WASH SYSTEMS

**RG-440
CONVEYOR**

PLASTIC GUIDE(OPTION)

PART NO. : 44-045-00-PP

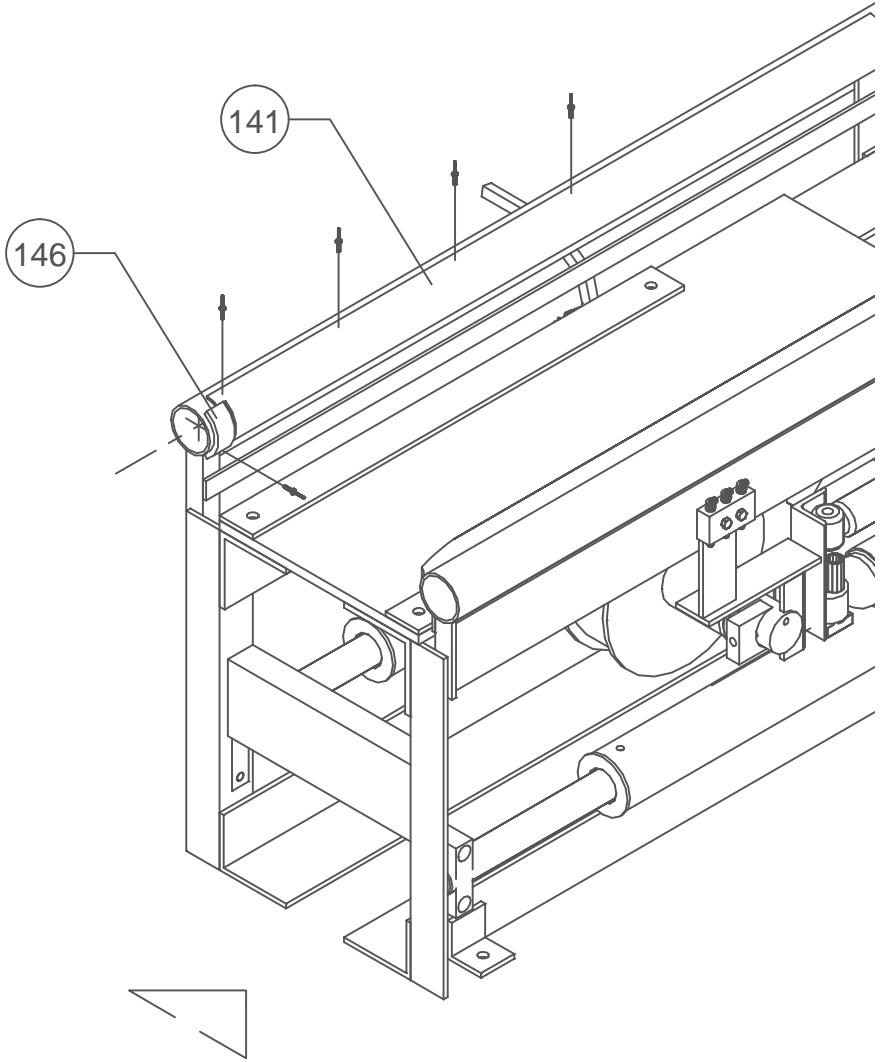

RG-440 CONVEYOR

PAGE #15

<i>Item no.</i>	<i>Req'd</i>	<i>Description</i>	<i>Part no.</i>	<i>Remarks</i>
1	1	Conveyor Entrance Frame	44-110-00-000-**	specify colour
1a	***	Conveyor Entrance Frame (Mirror Image)	44-150-00-000-**	Used For Mirror Image Frame
2	***	Conveyor Intermediate Frame	44-120-00-000-**	specify colour
3	1	Conveyor Exit Frame	44-130-00-000-**	specify colour
3a	***	Conveyor Exit Frame (Mirror Image)	44-160-00-000-**	Used For Mirror Image Frame
4	1	Slider Weldment DS	44-038-00-YL	
5	1	Slider Weldment PS	44-039-00-YL	
6	2	Slider Shaft	44-041-00-ZN	
7	2	Axle Cap	44-043-00-YL	
8	2	HHCS 3/8-16x3-3/4", SS	82-506-060-SIC	
9	28	Lock Washer 3/8", SS	80-906-000-SI	
10	4	Slider Bushing	44-040-00-MP	
11	4	Truss-Head Screw 1/4-20 x 1/2"	83-904-008-SIC	
12	2	Thrust Washer 2"	80-632-000-ZI	
13	2	Take-up Drum Bushing	44-032-00-MP	
14	1	Take-Up Drum	44-030-00-YL	
15	1	Axle Shaft	44-031-00-ZN	
16	4	Slider Shaft Holder	44-042-00-MP	
17	8	SHCS 3/8"-16X1", SS	82-506-016-SIC	
18	4	Tension Cylinder	44-034-00-MP	
19	2	Anchor Pin	44-035-00-ZN	
20a	1	Double Acting Air Cylinder	90-100-11-PP	
20b		Single Acting Air Cylinder	44-050-00-PP	
21	4	Swivel Elbow 1/8" NPT-1/4" Tube	90-223-02-PP	
22	1	Jam Nut 7/16-20, SS	84-107-000-SIF	
23	1	Bumper Stop	44-596-00-PP	
24	1	Entrance Cover Mat, Rubber	44-085-00-PP	
25	2	Strap Entrance Cover	44-095-00-YL	
26	8	HHCS 3/8"-16X1-1/4", SS	82-506-020-SIC	
27	16	Flat Washer 3/8", SS	80-106-000-SI	
28	1	Chain Sensor Magnet Mount Kit	44-567-01-MP	
29	1	Manual Call-Up Kit	44-460-00-YL	
30	1	Split Pin 5/16"X 1/2"LG	86-205-024-SI	
31	2	Fork Ass'y Pivot Bracket	44-052-00-MP	
32	2	Fork Pivot Bushing	44-054-10-MP	
33	1	Call up Fork YL	44-051-50-YL	
34	1	Fork Return Tension Spring	44-058-20-MP	
35	1	Fall Arm	44-058-00-MP	
36	1	High Collar Lock Washer, SS	81-206-000-SI	

RG-440 CONVEYOR

PAGE #16

Item no.	Req'd	Description	Part no.	Remarks
37	1	SHCS 3/8"-16X1-1/2", SS	82-706-024-SIC	
38	1	Nylon Thumb Screw 1/4"-20x1"	83-804-016-NIC	
39	1	Proximity Switch	44-555-00-MP	
40	6	Grease Fitting 1/8 NPT x 45 Deg.	44-133-05-PP	
41	6	CNCTR BR 1/8NPT-3/16TBE	44-133-07-PP	
42	4	Fitting Elbow 1/8NPT-3/16TBE	44-253-02-PP	
43	7	Flat washer 1/2", SS	80-108-000-SI	
44	2	Grease Manifold Block	44-130-01-MP	
45	1	Copper Tube, 120"	44-134-00-MP	
46	6	HHCS 3/8"-16X3/4", SS	82-506-012-SIC	
47	2	PHL PAN HD Screw #8-32x1", SS	83-508-016-SNC	
48	14	Lock Washer #8, SS	80-908-000-SN	
49	4	Flat Washer #8, SS	80-108-000-SN	
50	2	Reed Switch D-B 64L 24V AC	44-554-00-PP	
51	2	Reed Switch D-B 53L 24V DC	90-150-01-PP	
52	***	HHCS 1/2"-13X2", Plated	82-508-032-ZIC	3+2XNO. Of Intern. Frames
53	***	Hex Nut 1/2"-13, Plated	84-008-000-ZIC	2+2XNO. Of Intern. Frames
54	1	Hydraulic Motor	95-100-02-PP	
55	1	Gear Reducer	44-010-01-PP	
56	10	HHCS 1/2"-13X1-1/2", SS	82-508-024-SIC	
57	10	Lock Washer 1/2", SS	80-908-000-SI	
58	1	Hydraulic Motor O'ring	44-118-00-PP	
59	2	Safety Door Bushing	44-186-00-PP	
60	2	Safety Door MTG Bracket	44-197-00-YL	
61	1	Safety Door	44-188-10-YL	
62	8	HHCS 3/8"-16 x 1" SS	82-506-016-SIC	
63	2	Bumper Stop	44-081-00-PP	
64	4	Lock Washer 5/8", SS	80-910-000-SI	
65	6	Hex Nut 5/8"-11, SS	84-010-000-SIC	
66	4	Stover Nuts	84-308-000-ZIF	
67	***	Bumper Stop Ass'y	44-099-00-MP	
68	1	Exit Cover Plate	44-089-00-BK	
69	1	Drive Sprocket	44-015-00-YL	
70	1	Rotary Encoder Body	44-582-00-BK	
71	1	Rotary Encoder Magnet Disk Ass'y	44-580-00-MP	
72	2	Rotary Encoder Bushing	44-587-00-PP	
73	1	Encoder Sprocket Plate	44-585-00-MP	
74	2	Nylock Nut SS 1/2"-13	85-008-000-SIC	
75	1	Rotary Encoder Drive Hose	44-586-00-MP	
76	***	Rotary Encoder Ass'y Kit 24V DC	44-584-00-MP	
77	***	Rotary Encoder Ass'y Kit 24V AC	44-588-00-MP	

RG-440 CONVEYOR

PAGE #17

<i>Item no.</i>	<i>Req'd</i>	<i>Description</i>	<i>Part no.</i>	<i>Remarks</i>
78	1	HHCS 3/4"-16X8" Plated Axle Bolt	82-512-128-ZIF	
79	4	Washer 3/4" Flat Shim	80-512-000-SI	
80	4	Bushing Axle	44-268-00-PP	
81	2	Outrigger Wheel, Red	44-162-00-PP	
82	2	3/4" Thrust Washer SS	80-612-000-SI	
83	2	Wheel Pusher, Yellow	44-063-00-PP	
84	1	Nut PI Flexloc Axle 3/4"-16	85-212-000-ZIF	
85	1	Forged Lug	44-161-00-PP	
86	***	Chain	44-067-00-PP	
87	1	Enclosure Box	44-571-01-MP	
88	1	Enclosure Box Back Plate	44-571-02-MP	
89	5	Push Button- Rectangular	44-525-00-MP	
90	5	Light Bulb 28VAC	44-544-00-PP	
91	1	Decal Control Station(8-Push Button)	36-440-00-PP	
92	1	1/4" Tube-1/4"NPT Swivel elbow	90-223-06-PP	
93	3	1/8" NPT F/F Brass Elbow	44-561-10-PP	
94	1	Air Gauge 0-160PSI	90-160-00-PP	
95	5	Fitting 1/8" NPT Close Nipple Brass	44-561-09-PP	
96	2	Pressure Regulator	44-101-01-PP	
97	1	1/2" Hose Block Plate Weld	90-156-10-MP	
98	2	1/4" SS Lock Washer	80-904-000-SI	
99	2	1/4" SS Flat Washer	80-104-000-SI	
100	1	Air Pressure Gauge 0-60 psi	90-060-00-PP	
101	1	1/4" NPT CNTRSNK Brass Plug	90-052-04-PP	
102	2	Fitting Elbow 1/4" Tube- Socket PLJ1/4	90-222-00-PP	
103	1	Solenoid Valve 24V DC	90-134-00-PP	
104	1	Solenoid Valve 24V AC	90-134-00-PP	
105	***	Manual Call-Up Ass'y	44-953-00-MP	
106	1	1/4" NPT Brass Nipple 3" Lg	90-216-03-PP	
107	1	1/2" Single Hose Block Plate	90-156-01-PP	
108	2	1/2" Single Hose Block Pair	90-156-00-PP	
109	1	1/8" NPT Female Brass Tee	90-009-02-PP	
110	1	Pressure Switch	44-128-00-PP	
111	1	Solenoid Valve Jack SY-100-30-4A	90-134-01-PP	
112	1	Treadle Switch	44-025-00-PP	
113	6	Strain Relief 1/2"-20	44-584-08-PP	
114	1	Micro Switch	44-530-00-PP	
115	6	PHL PAN HD Screw #8-32X1/4	83-508-004-SNC	
116	***	Roller Ass'y	44-060-00-MP	
117	1	Ladder Tray 5-3/4"Lg	44-571-05-MP	

RG-440 CONVEYOR

PAGE #18

<i>Item no.</i>	<i>Req'd</i>	<i>Description</i>	<i>Part no.</i>	<i>Remarks</i>
118	1	Ladder Tray 7-3/4" Lg	44-571-06-MP	
119	1	Ladder Tray 12-1/2"	44-571-07-MP	
120	1	DIN Rail 8" Lg	44-562-03-MP	
121	1	DIN Rail End Stop(1201442)	70-600-00-PP	
122	1	PLC (Cutler Hammer D50)	70-675-00-PP	
123	1	Relay Base PTF08A-E	70-602-00-PP	
124	1	Relay Omron	70-670-02-PP	
125	10	Terminal Marker	70-600-02-PP	
126	1	DIN Rail End Stop UK 2,5N	70-600-01-PP	
127	3	DIN Rail End Separator	70-601-00-PP	
128	1	DIN Rail Grounding Post	70-605-00-PP	
129	1	Hose 3/8 Drive way Signal	33-042-00-6BK	
130	2	Wire strap 4" Lg	44-561-14-PP	
131	1	Treadle Block	44-120-00-BK	
132	1	Treadle End Block	44-125-00-BK	
133	2	3/8" Tube, 1/4" NPT Hose Barb	44-124-00-PP	
134	2	Fitting Tee 1/8" TBE-1/8" NPT	44-136-00-PP	
135	1	Air Filter	90-120-01-PP	
136	1	Lubricator	90-122-01-PP	
137	1	Air Filter/Lubricator MTG Bracket	90-121-01-PP	
138	1	3/8" NPT-1/4" tube	90-230-07-PP	
139	6	HHCS 1/4"-20X1", SS	82-504-016-SIC	
140	***	Treadle Ass'y Kit	44-921-00-MP	
141	***	Plastic Guide Rail Kit	75-440-45-MP	"OPTION"
142	1	Air Manifold Block	44-036-01-BK	
143	1	Modified Cap 118-B	90-061-04-MP	
144	1	1/4npt-1/4tbe Straight Fitting	90-025-00-PP	
145	2	1/8npt-1/4tbe Swivel Fitting	44-158-00-PP	
146	1	Guide Rail Cover Mounting Bracket	44-002-01-MP	
147	2	Hydraulic Fitting 854-FS-08-06	95-030-07-PP	
148	4	3/8 I.D. x 1.5 O.D. S.S. Washer	80-706-000-SI	
149	1	3/4-16 JAM NUT SS	84-112-000-SIF	