

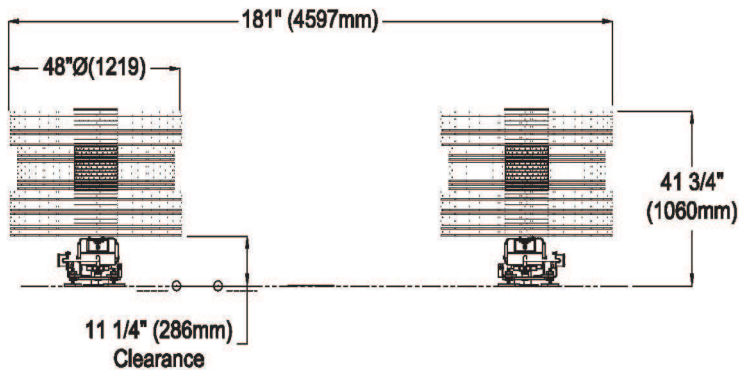

RS400 Side Washer

Electric Drive

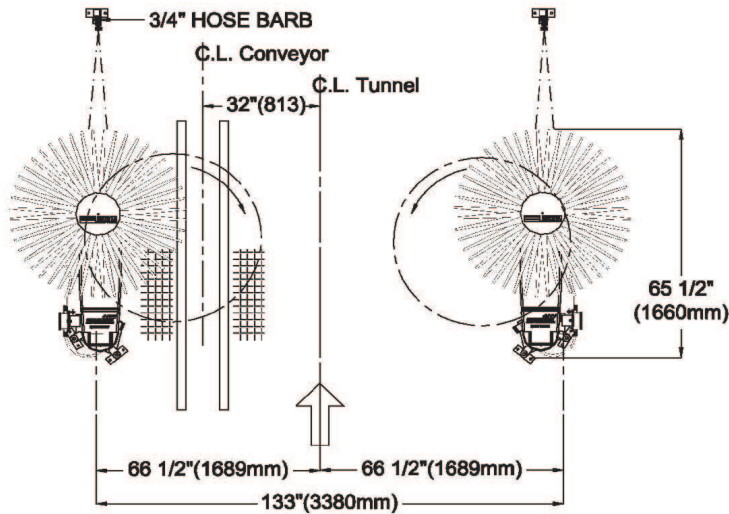

Features

- 2ND Generation Foam
- Individually Air Controlled Side Pressure
- Direct Drive / Flanged Core
- Stainless Steel bearings and hardware
- Epoxy Powder Coated Aluminum Structure
- Solenoid Valve – Optional Voltage
- One Year Manufacturer warranty

Options

- Retract System
- 2nd Generation Foam – Red or Blue

Technical Data

Electric

- Motor - 208/230/460V, 60 Hz, 3 ph-0.9 kW
- VFD – 200V, 60 Hz, Single Phase 0.75 kW
- VFD Control – 24 VAC
- Retract Control – 24 VAC

Water

- 3/4" Line (hose Barb on Spray Bar)
- 40 PSI (3 BAR) Min. Pressure
- 4.5 GPM (17 LPM) / Brush

Pneumatics

- 1/4" Line (Quick Connect on Cylinder)
- 0.5 CFM (0.014 cu M/Min)
- 60 PSI (4 BAR)

Operating Parameters

- 100 RPM Brush Speed
- 50-150 CPH (Cars per Hour)
Line Speed Capability

Specifications Subject To Change. Information Provided is For Reference Only and is Not To Be Used For Installation or Construction Purposes. Refer to MacNeil Wash Systems Equipment Drawings For Installation Specifications. JANUARY 2005.