

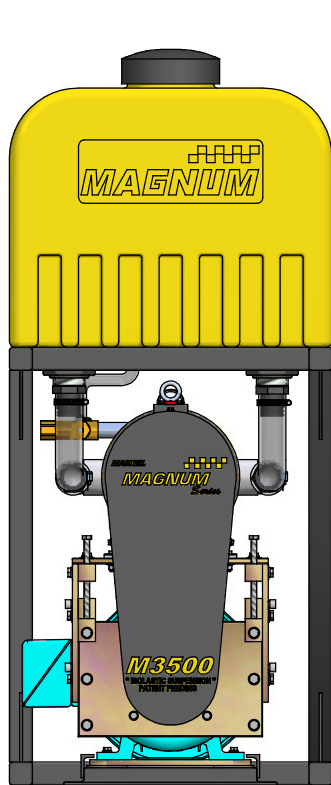

# M3500R MAGNUM PUMP STATION

MAGNEIL   
MAGNUM  
Series



**FRONT VIEW**

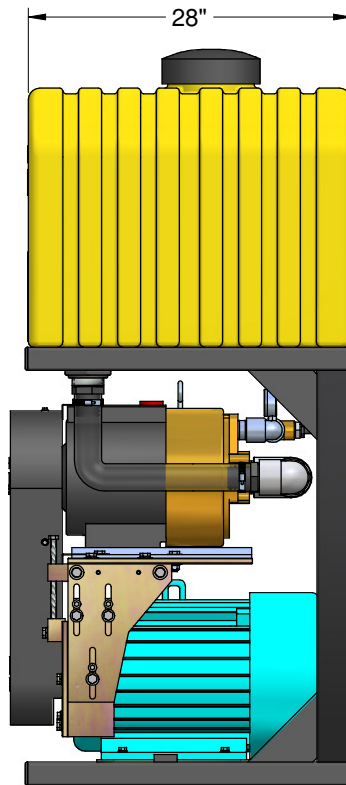

**SIDE VIEW**

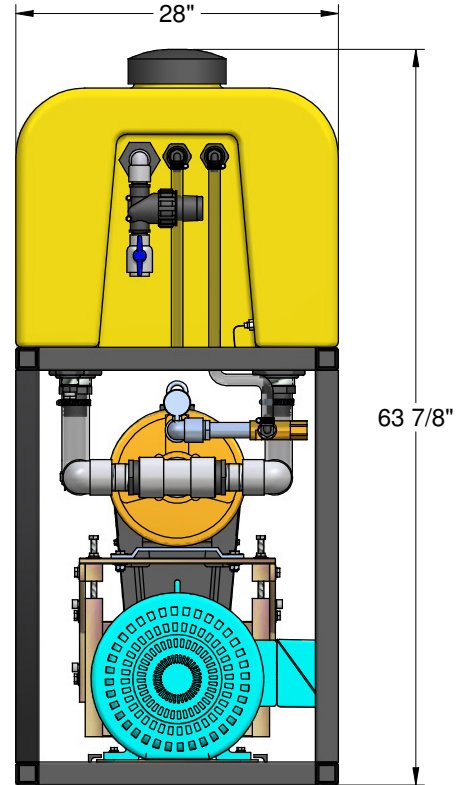

**BACK VIEW**

**PURPOSE:**

- TO PROVIDE SUPERIOR QUALITY HIGH PRESSURE SUPPORT EQUIPMENT FOR ALL EQUIPMENT NEEDS

**FEATURES:**

- HIGH PRESSURE EQUIPMENT SYSTEM SUPPLY
- SYSTEM LINE PRESSURE OF UP TO 1000 PSI
- OUTPUT CAPACITY OF 8GPM
- 50 US GALLON WATER CAPACITY
- LOW LEVEL WATER SENSOR

**OPTIONS:**

- REFER TO MAGNUM SERIES PUMP STATIONS
- M1000R - 8 GPM / 7.5 HP
- M2000R - 20 GPM / 15 HP

**TECHNICAL DATA:**

**ELECTRIC MOTOR:**

- 575 VAC, 60Hz
- RATED OUTPUT = 25HP
- FULL LOAD SPEED = 1770 RPM
- THREE PHASE, 4 POLE
- CONTINUOUS DUTY

**SYSTEM PUMP:**

- MAX. SPEED CAPACITY = 1150 RPM
- MAX. FLOWRATE = 34.5 GPM
- DELIVERY AT MAX. PSI = 29 REV/USG
- MAX. INLET PRESSURE = 250 PSI
- MAX. DISCHARGE PRESSURE = 1000PSI
- 2-1/2" NPT INLET PORT
- 1-1/4" NPT DISCHARGE PORT

**TANK SENSOR:**

- LOW LEVEL ALARM

**WATER:**

- 1" HIGH PRESSURE SYSTEM LINE
- 3/4" OVERFLOW LINE
- 3/4" UNLOADER LINE TO TANK
- 2 x 2" PUMP INLET LINE

SPECIFICATIONS SUBJECT TO CHANGE. INFORMATION IS PROVIDED FOR REFERENCE ONLY AND IS NOT TO BE USED FOR INSTALLATION OR CONSTRUCTION PURPOSES. REFER TO MACNEIL WASH SYSTEMS EQUIPMENT DRAWINGS FOR INSTALLATION SPECIFICATIONS. REVISED MARCH 22, 2006.

**REV 'A'**