

LAYOUT

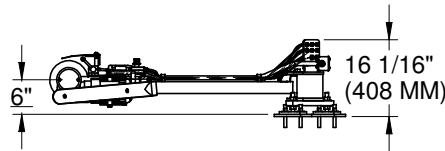
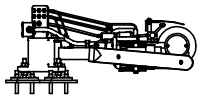
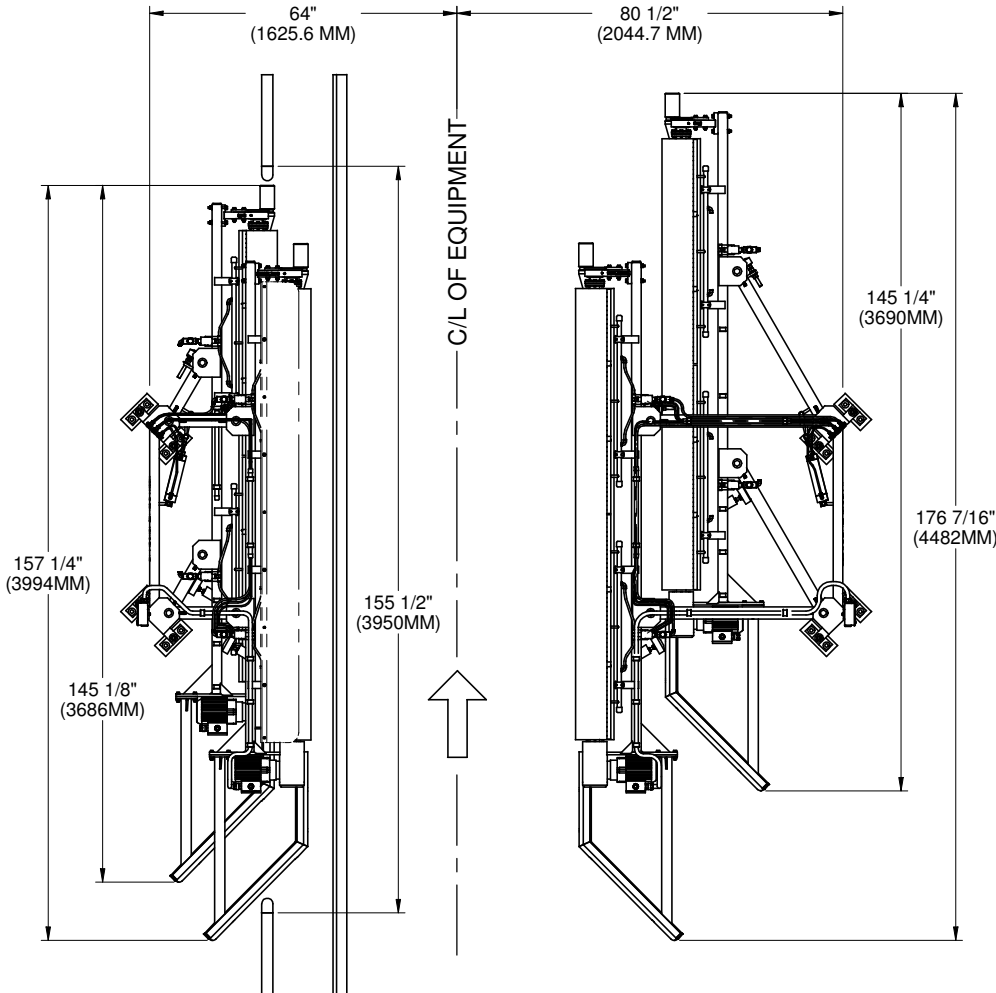

SIDE VIEW

FEATURES:

- Maintenance-Free Pro-Coat Finish
- Stainless Steel Hardware
- Electric Drive
- Split End Ultra Soft Bristle Brush
- Individually Controlled Side Pressure
- One Year Manufacturer Warranty

OPTIONS:

- Chemical Splash Guard
- Boost panel

TECHNICAL DATA:

Electric Motor:

- IP-65 Electric Motor
- 3 Phase - 208/230/460 VAC 60HZ
- 75 RPM

Chemical:

- Two Ounces Per Vehicle (60ml)

Pneumatics

- 1/4" (6.35mm) Cyl. Lines
- 0.5 CFM (0.014m³/Min.)
- Supply 50psi (3.4 bar)

Control Voltage:

- 24VAC Control Voltage Signal
- 110VAC Available on Special Request

SPECIFICATIONS SUBJECT TO CHANGE. INFORMATION IS PROVIDED FOR REFERENCE ONLY AND IS NOT TO BE USED FOR INSTALLATION OR CONSTRUCTION PURPOSES. REFER TO MACNEIL WASH SYSTEMS EQUIPMENT DRAWINGS FOR INSTALLATION SPECIFICATIONS. REVISED NOVEMBER 7, 2008.