

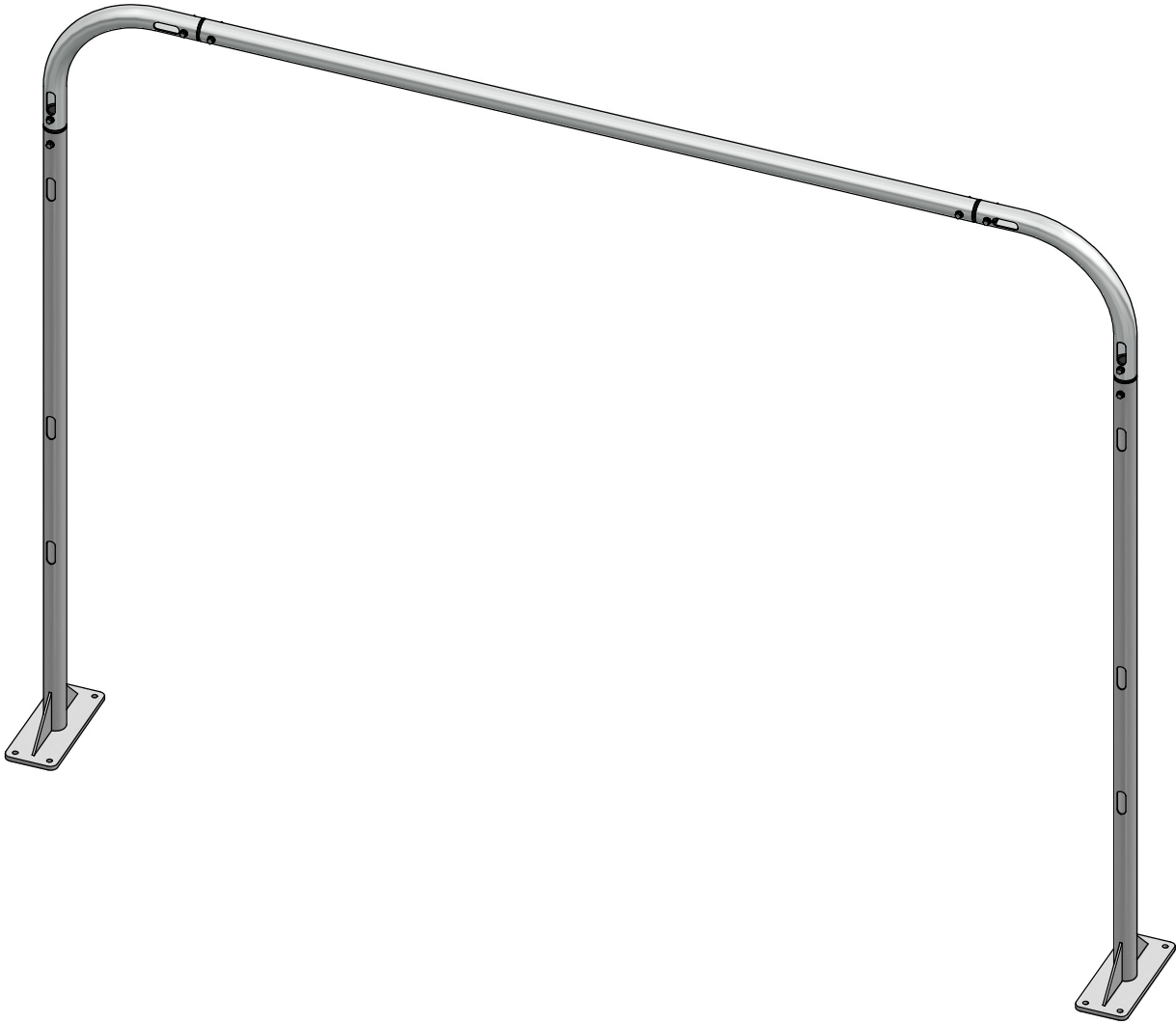

RW111 ROUND PLUMBING ARCH
46-R00-00-00



90 Welham Road, Barrie, Ontario 705-722-7649

TITLE RW111 ROUND ARCH		
PART NO EPL 46-R00-00-00	DWG NO EPL 46-R00-00-00	REV C
DATE: SEPT 19, 2008		SHEET 1 OF 3

MacNeil Wash Systems- Parts List

RW111 ROUND PLUMBING ARCH

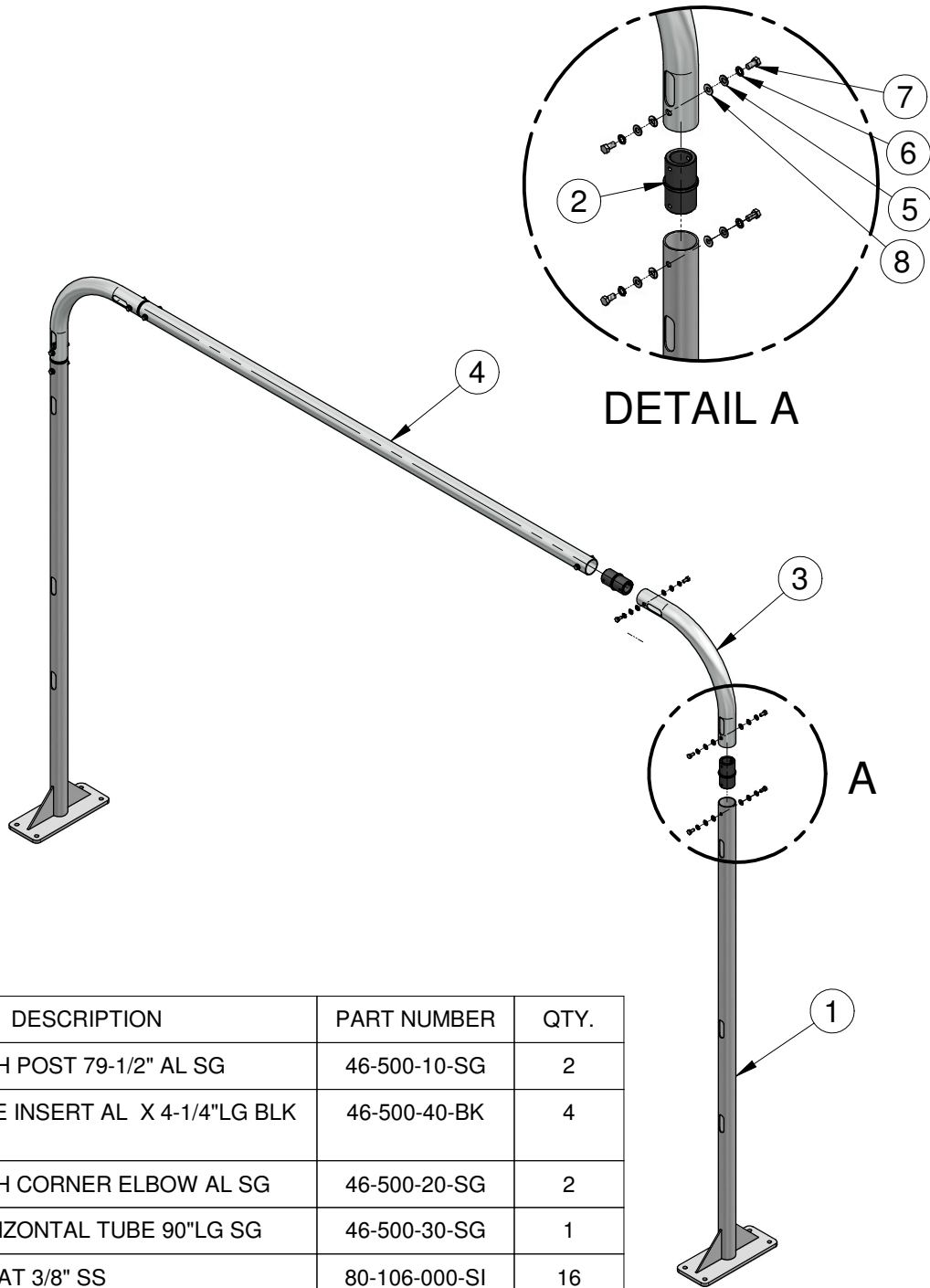

REF.	DESCRIPTION	PART NUMBER	QTY.
1	RW111 ARCH POST 79-1/2" AL SG	46-500-10-SG	2
2	RW111 TUBE INSERT AL X 4-1/4"LG BLK ANO	46-500-40-BK	4
3	RW111 ARCH CORNER ELBOW AL SG	46-500-20-SG	2
4	RW111 HORIZONTAL TUBE 90"LG SG	46-500-30-SG	1
5	WASHER FLAT 3/8" SS	80-106-000-SI	16
6	LOCK WASHER 3/8" SS	80-906-000-SI	16
7	HHCS SS 3/8"-16 X 3/4"	82-506-012-SIC	16
8	WASHER NY 3/8"OD X 13/16"OD X 1/16"THK WHT	80-106-000-NI	16
9*	ADHESIVE SEALANT 'SURE CHECK' LSC 9019 CLR 5OZ TUBE (*NOT SHOWN*)	33-725-10-PP	1



90 Welham Road, Barrie, Ontario 705-722-7649

TITLE RW111 ROUND ARCH		
PART NO EPL 46-R00-00-00	DWG NO EPL 46-R00-00-00	REV C
DATE: SEPT 19, 2008	SHEET 2 OF 3	

MacNeil Wash Systems- Parts List

RW111 ROUND PLUMBING ARCH FIELD ASSEMBLY PROCEDURE

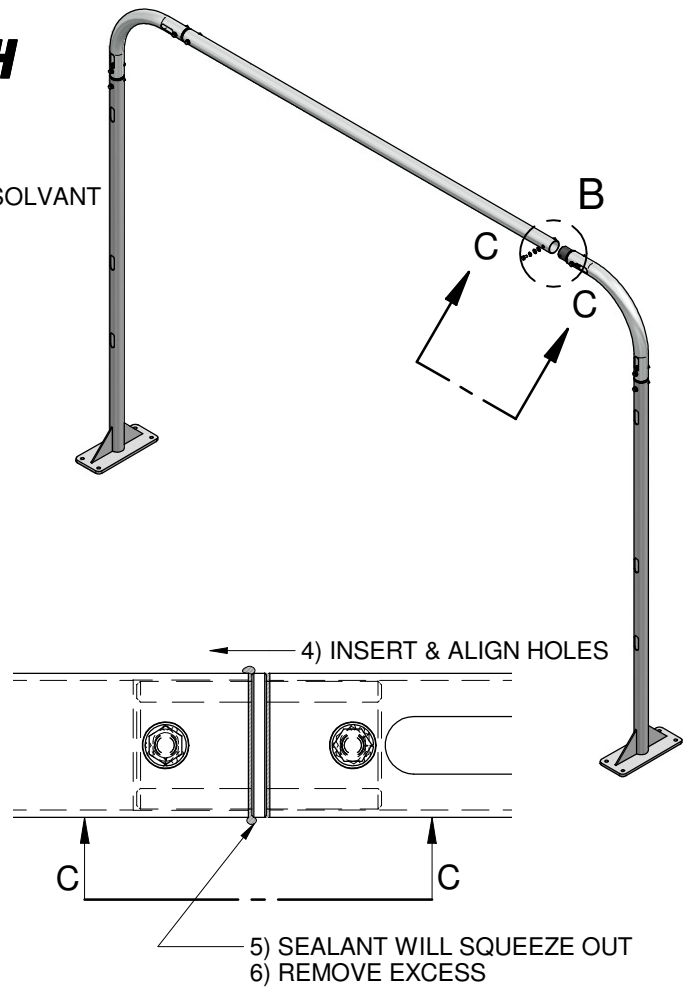
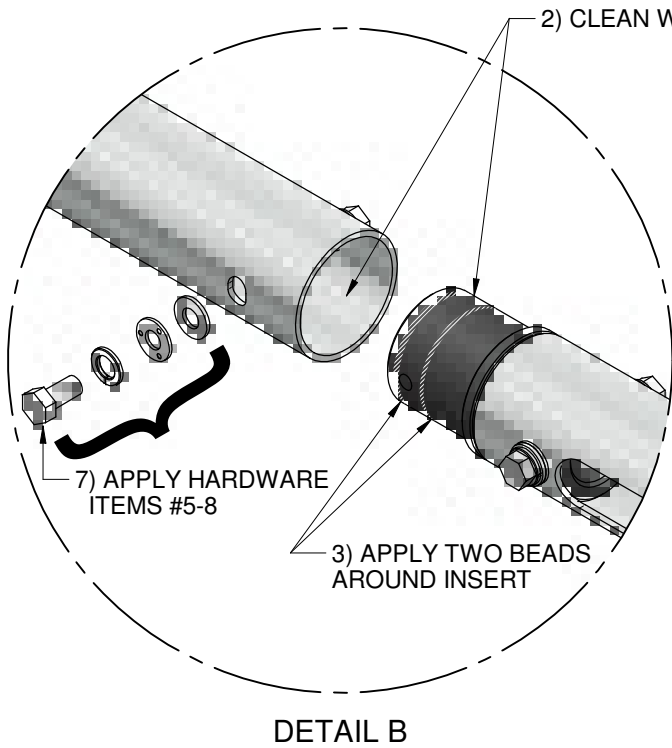

FOR ARCH ASSEMBLY, FOLLOW LISTED INSTRUCTIONS:

- 1) USE SEALANT 33-725-10-PP SURE CHECK ADHESIVE. ITEM #9
- 2) BEFORE INSERTS ARE CONNECTED,
CLEAN OUTSIDE OF INSERT & INSIDE OF TUBE WITH SOLVENT CLEANER.
- 3) APPLY TWO (2) BEADS OF SEALANT 33-725-10-PP TO BLACK INSERT, AS SHOWN.
- 4) PUSH THE INSERT INTO THE TUBE, UNTIL HOLES ARE ALIGNED.
- 5) SEALANT WILL SQUEEZE OUT AT THE SEAM.
- 6) REMOVE EXCESS SEALANT FROM JOINT.
- 7) APPLY HARDWARE TO HOLD THE INSERT IN PLACE.

**THIS PROCEDURE HAS ALREADY BEEN APPLIED
AT THE FACTORY ON PRE-JOINTED CONNECTIONS.*

MacNeil Wash Systems- Parts List



90 Welham Road, Barrie, Ontario 705-722-7649		
TITLE RW111 ROUND ARCH		
PART NO EPL 46-R00-00-00	DWG NO EPL 46-R00-00-00	REV C
DATE: SEPT 19, 2008	SHEET 3 OF 3	