



SONIC
WHEEL WASHER BY MACNEIL

Demand Cleaner Rims

www.macneilwash.com
1-800-361-7797

Brake Dust Finally Meets Its Match

Sonic takes on brake dust with no demands on your workforce

With the convergence of alloyed rims and softer brake pad compounds, brake dust has become a universal problem faced by wash operators and frustrated car owners. Brake “dust” is actually a combination of carbon fibres, metal filings and – the real culprit – polymer adhesives. The adhesives cause a greasy, grimy build-up to stick to the wheels: left unattended it can cause serious damage.

Until now the fight against brake dust hasn't delivered a knock-out punch. Tire brushes tend to clean just the rubber, but not the rims. High-pressure applications go part way but typically can't tackle the really greasy black residue. As a result, customers seeking clean, shiny alloys have been

continually disappointed, leaving operators to resort to costly manual labor in the quest to satisfy.

“It's like a beacon to customers who immediately know that this is a quality clean.”

Sonic Delivers a Knock-Out

With the introduction of the RS-500 Sonic Wheel Washer, brake dust finally meets its match. Coupled with quality chemicals and finished with high-pressure rinsing, Sonic delivers the most extreme clean for blackwalls and alloyed rims. A fully automatic system, Sonic does away with costly manual labor, transforming wheel

washing into a potential profit center as a premium wash add-on. An added bonus is that – in the process – Sonic cleans the entire lower detail areas from the wheel down, including rocker panels, lower doors and fenders.

Sonic is extremely simple to install and maintain in new and existing tunnels. It features MacNeil Wash Systems' industry respected Quiet Drive technology with variable frequency drives and Envirosoft foam for quiet, effective, gentle cleaning. But don't let its soft side fool you: Sonic truly puts the boots to brake dust.

Get the Best Wheel Washer. Get MacNeil.

GREAT IDEAS • GREAT RESULTS



PUT BRAKE DUST IN ITS PLACE WITH THE RS-500 SONIC WHEEL WASHER BY MACNEIL

> THE MACNEIL ADVANTAGE

- Innovatively designed and engineered product
- Envirosoft foam material aggressively cleans alloy rims, tires and lower detail areas
- Sends brake dust packing with an effective, automated solution
- Combat brake dust without costly manual labor
- Make wheel cleaning a profit center
- Gives customers the clean wheels they are demanding



> FEATURES

- Load sensing technology for consistent cleaning pressures
- Auto retract for safety
- Most effective cleaning for wheels and rocker panels
- Easy to install & maintain in new or existing tunnels
- MacNeil quiet drive technology (electric) with variable frequency drive (vfd) – not available in hydraulic drive
- MacNeil standard design & engineering features such as:
 - Envirosoft foam - effective cleaning yet quiet & gentle
 - Maintenance-free Pro-Coat finish
 - Stainless steel hardware
 - One year manufacturer's warranty

> TECHNICAL DATA

Electric Motor

- 208/230/460 VAC, 60Hz
- Three phase, 0.9 kW

Control Voltage

- 24 VAC

Electrical Variable Frequency Drive

- 200 VAC, 60Hz
- Single phase, 1.1kW

Water

- Line 3/4"
- 4 GPM (15.14 LPM) / brush @ 40 PSI (2.7 BAR)

Pneumatics

- Line 1/4"
- 0.5 CFM (0.014 m3/min)
- 100 PSI (6.9 BAR)

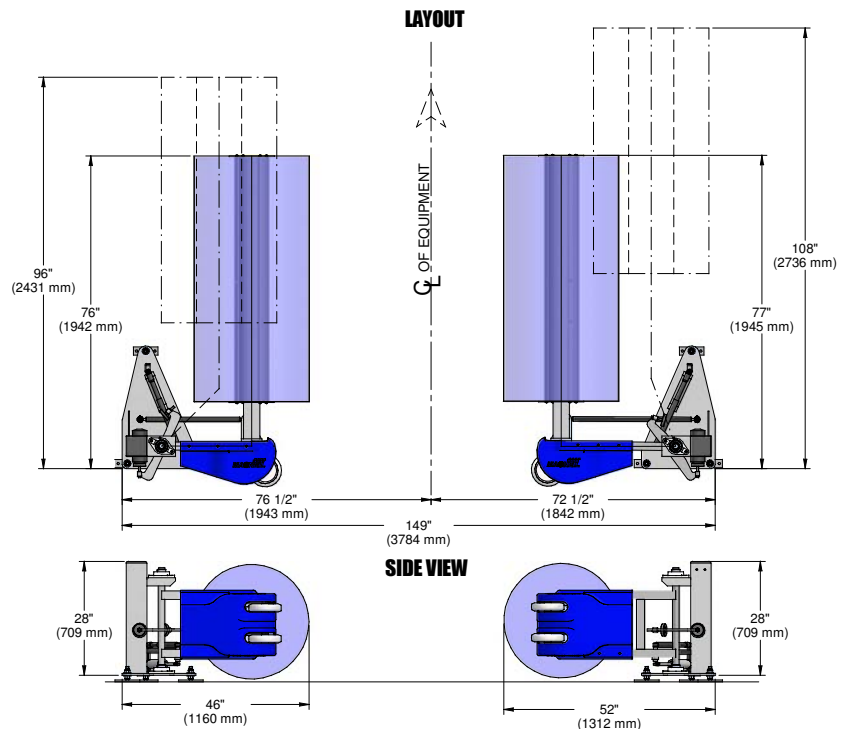

> ABOUT MACNEIL WASH SYSTEMS

MacNeil Wash Systems was established in 1982. The Company designs and manufactures quality car wash systems for the tunnel car wash industry and for the automotive dealer, fleet and rental markets. MacNeil products are engineered to provide superior cleaning performance, reduced maintenance, increased production, maximum cost savings and equipment longevity. All MacNeil equipment is backed by our focus on service excellence. We distribute and support our products through a North American network of more than 40 distributors that is second to none in capability and performance.

To find out more about the Sonic Wheel Washer, visit www.macneilwash.com or call us toll-free at 1-800-361-7797

Specifications subject to change. Information is provided for reference only and is not to be used for installation or construction purposes. Refer to MacNeil Wash Systems equipment drawings for installation specifications.